

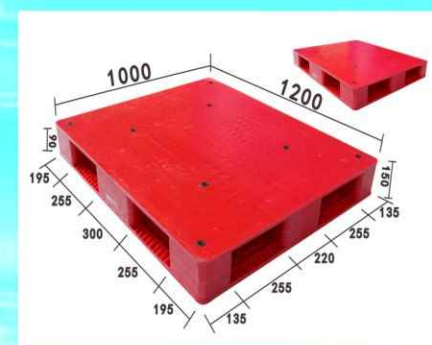

广东奇力智能设备有限公司
GUANGDONG ORION INTELLIGENT EQUIPMENT LIMITED



仓储设备
Storage Equipment



GUANGDONG ORION INTELLIGENT EQUIPMENT LIMITED
广东奇力智能设备有限公司

Factory ADD: No. 3 East Shengli Road, Pingzhou Industrial Park, Guicheng,
Nanhai District, Foshan City, Guangdong Province, China

工厂地址: 广东省佛山市南海区桂城平洲工业园胜利路3号

Mobile: +86-13424131725

Contact: Jasmine Zhao

Tel: +86-20-29842552

Skype: jasminezha0888 WhatsApp: +86-13424131725

E-mail: jasminezha0@orionrack.com

jasminezha0888@foxmail.com

Website: <http://www.orionrack.com>

<https://orionrack.en.alibaba.com>



Website



Sales Wechat

Web: <http://www.orionrack.com>

<https://orionrack.en.alibaba.com>

中国·广东

企业简介 ORION >>>

ENTERPRISE BRIEF INTRODUCTION



GUANGDONG ORION INTELLIGENT EQUIPMENT LIMITED has focused on the R&D, design, production, sales and after-sales service of high-quality warehousing and logistics equipment system solutions since 2003. Now we have become one of the leading suppliers in the racking system and storage equipment in China. Our products mainly include: pallet racks, medium-duty racks, light-duty racks, drive-in racks, radio shuttle racks, push-back racks, cantilever racks, mezzanine floor (steel platforms), mezzanine racks, carton flow racks, mould racks, tool cabinets, heavy duty workbench and other storage equipment.

We have two factories, located in Foshan and Dongguan City, Guangdong province. The total production is about 55000 square meters, and the annual production capacity is about 100,000 tons. We have more than 20 sets of rolling production lines, multiple sets of welding robots and 4 sets of fully automatic powder coating lines.

ORION has strong technical force and product development ability, more than 100 professional senior technicians, including 50 senior design and planning engineers, 27 project implementation engineers, and 15 professional after-sales service teams, providing customers with the most professional program design, to ensure the rapid response of customer site installation management and equipment use.

Through years of continuous efforts, our customers are all over the world, Now, we have become one of the largest and important providers in this field in Southeast Asia, Middle East, Australia, Europe, North America, South Africa and other overseas markets. We have extensive experience in supporting services for medium and large companies and have undertaken thousands of projects in both domestic and international markets. As a global supplier of warehouse racking systems and storage equipment, ORION creates added value for our customers worldwide.

广东奇力智能设备有限公司，成立于2003年。公司专注于高品质仓储物流设备系统方案的研发设计，生产，销售及售后服务，现如今已经成为中国优质货架系统和仓储设备行业的供应商之一。主要产品包括：横梁式货架、中型货架、轻型货架、驶入式货架、穿梭式货架、后推式货架、悬臂式货架、钢平台、阁楼货架、流利式货架、模具架、工具柜、重型工作台等物流设备。

奇力设有两家工厂，分别位于佛山和东莞。总生产面积约55000平方米，年生产力约10万吨。我们拥有20多套滚轧生产线，多套焊接机器人和4套全自动粉末喷涂线。

奇力具备雄厚的技术力量和产品开发能力，专业高级技术人员100多名，其中设计策划高级工程师50人，项目实施工程师27人，专业的售后服务团队15人，为客户提供最专业的方案设计，保障客户现场的安装管理和设备使用的快速响应。

经过多年的努力，我们的客户遍布全球，已成为东南亚，中东，澳洲，欧洲，北美等海外市场最大和最忠诚的供应商。我们拥有丰富的大中型企业配套服务经验，已在国内外市场承接了上千个项目。作为仓库货架系统和仓储设备的全球供应商之一，奇力为全球客户创造更多附加值。



奇力，品质缔造价值！

ORION, QUALITY CREATES VALUE!

我们的团队 OUR TEAM >>>

•With excellent technology and a serious attitude in every project , we providing the high-quality products and best service to all of our customers. What we pursue is not only honor, but also customer recognition.

•我们以过硬的技术，认真的态度抓好每一项工程项目，为我们的新老客户提供优质产品和服务！我们追求的不仅仅是荣誉，更是客户的认可。



Product symposium
产品研讨会



Shearing steel plate
剪板



Professional loading container team
专业装柜团队



ORION certificate
奇力荣誉



Company regular meeting
公司例会



Customer project review meeting
客户专案讨论会



Installation of radio-shuttle racking
穿梭式货架安装



Factory office
工厂办公室

奇力 品质缔造价值



PRODUCTION EQUIPMENT

◎ 生产设备

• 20 Years Industry Experience, Profession Manufactory
 .pallet racks, medium-duty racks, light-duty racks, drive-in racks, radio shuttle racks, push-back racks, cantilever racks, mezzanine floor (steel platforms), mezzanine racks etc.

• 20年行业经验，专业生产厂家
 • 横梁式货架、中型货架、轻型货架、驶入式货架、穿梭式货架、后推式货架、悬臂式货架、钢平台、阁楼货架等。



The warehouse of finished goods
成品仓



Raw material zone
原料间



Punching machine
冲床



Bending machine
折弯机



Automatic welding machine
自动焊接机



Painting line
喷涂线

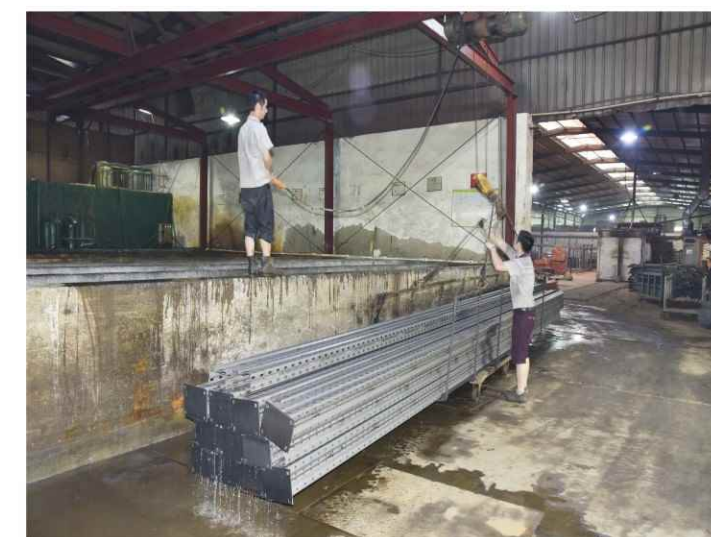

Pickling treatment
酸洗

目录/CONTENTS

Storage Equipment 仓储设备

Station Equipment 工位器具

09 Tool Cabinet
工具柜

13 Tool Trolley
工具车

17 Workbench
工作台

21 Storage Cabinet
置物柜

25 Material Sorting Rack
物料整理架

27 Steel File Cabinet
钢制文件柜

Logistic Equipment 物流器具

29 Wire Mesh Storage Cage
仓储笼

31 Steel Material Container
钢制料箱

33 Folding Logistics trolley
折叠式物流周转车

35 Stacking Frame
堆垛架

38 Accessory Box
零件盒

39 Plastic Pallet
塑料托盘

43 Turnover Box
周转箱

45 Steel Pallet
钢托盘

47 Wooden Pallet
木托盘

Transport Equipment 搬运设备

49 Trolley
手推车

51 Manuel Pallet Truck
手动搬运车

52 Semi-Electric Stacker
半电动堆高车

54 Electric Stacker
全电动堆垛车

57 Forklift
叉车

合作客户 OUR CUSTOMERS >>>



Station Equipment 工位器具

TOOL CABINET

◎ 工具柜

Product Features:

- The drawers and cabinets are made of 1.2mm cold-rolled steel, which is treated with phosphate and then coated with electrostatic powder baking paint to achieve anti-rust effect.
- High-strength double guide rail drawer, with a maximum load-bearing capacity 200kgs per drawer, which can be opened by 90%-100%;
- The space in the drawer can be separated by Partition plate;
- Full-width aluminum alloy handle, with replaceable labels, beautiful and practical;
- The safety buckle design of the drawer ensures that the drawer will not slide out accidentally after closing;
- Advanced central lock, one key can open and close all drawers;
- A variety of cabinets and drawers can be combined freely to meet different needs;
- The bottom of the cabinet is equipped with foot pads to protect the cabinet and facilitate handling.



产品特性:

- 抽屉及箱体均使用1.2mm冷轧钢板，经磷酸盐处理后，外加静电粉体烤漆，以达到防锈效果。
- 高强度双导轨抽屉，最大承重达200kgs每抽，可90%-100%打开；
- 抽屉内可随意分隔空间；
- 全宽型铝合金把手，配合可更换的标签，美观实用；
- 抽屉安全扣设计，保证抽屉关闭后不会意外滑出；
- 先进的中央锁具，一把钥匙能开关所有抽屉；
- 多种规格的柜体及抽屉可自由组合，满足不同的使用需求；
- 柜体底部配脚垫，保护柜体且方便搬运。

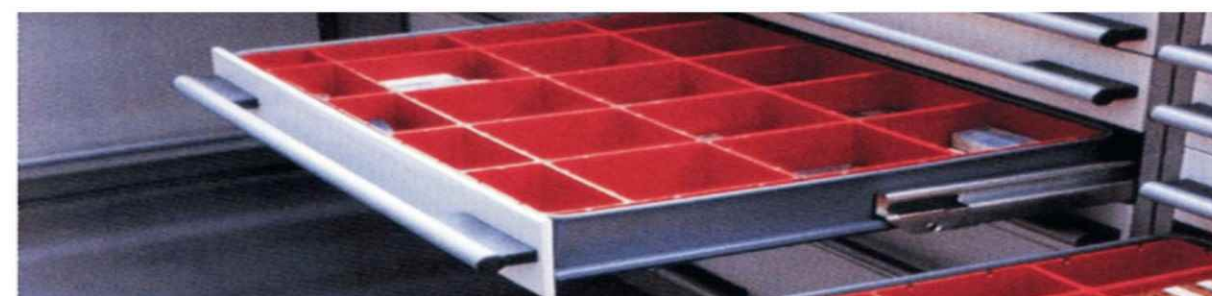

Station Equipment 工位器具

TOOL CABINET

◎ 工具柜

工具柜常规尺寸表
Tool Cabinet Standard Size Sheet

名称 Name	Specifications(mm)			抽屉数量 (Drawer QTY) pcs	抽屉承载 (Drawer's Load Capacity) KGS	备注 (Remarks)
	宽度(Width)	深度 (Depth)	高度(Height) included the feet height			
Tool Cabinet 工具柜	600	545	585/665/745/825	4/4/5/5	90/150	Material: high quality cold rolling steel Q235B(SS400); Surface treatment: deoil, derusting and powder coat paint finish; Color: standard blue, orange and customized available
	600	545	825/1105/1305	6/7/8	90/150	
	760	705	585/665/745/825	3/4/5/5	90/150	
	760	705	825/1105/1305	6/7/8	90/150	
	760	545	585/665/745/825	4/4/5/5	90/150	
	760	545	825/1105/1305	6/7/8	90/150	
	1000	545	585/665/745/825	3/4/5/5	90/150	
	1000	545	825/1105/1305	6/7/9	90/150	
	1000	705	585/665/745/825	4/4/5/5	90/150	
	1000	705	825/1105/1305	6/7/8	90/150	



aluminum alloy handle



double guide rail drawer



partition plate



central lock

Station Equipment 工位器具

TOOL TROLLEY

◎ 工具车

Product Features:

- Sturdy casters can withstand the impact of uneven ground;
- High-strength double guide rail drawer, the maximum load-bearing capacity is 150kgs, which can be opened 90%- 100%;
- The space in the drawer can be separated by Partition plate;
- Full-width aluminum alloy handle, with replaceable labels, beautiful and practical;
- The safety buckle design of the drawer ensures that the drawer will not slide out accidentally after closing;
- Advanced central lock, one key can open and close all drawers;
- Universal wheels with brakes, safe and stable;
- The top is covered with 2.0 black rubber.

产品特性:

- 坚固的脚轮能经受不平整场地的冲击;
- 高强度双导轨抽屉, 最大承重达150kgs, 可100%打开;
- 抽屉内可随意分隔空间;
- 全宽型铝合金把手, 配合可更换的标签, 美观实用;
- 抽屉安全扣设计, 保证抽屉关闭后不会意外滑出;
- 先进的中央锁具, 一把钥匙能开关所有抽屉;
- 带刹车的万向轮, 安全稳固;
- 顶部铺2.0黑色胶皮。



drawer



handing board



central lock



aluminum alloy handle



Station Equipment 工位器具

TOOL TROLLEY

◎ 工具车

工具车常规尺寸表
Tool Trolley Standard Size Sheet

名称 Name	Specifications(mm)			抽屉数量 (Drawer QTY) pcs	抽屉承载 (Drawer's Load Capacity) KGS	备注 (Remarks)
	宽度 (Width)	深度 (Depth)	高度(Height) included the castor height			
Tool Trolley 工具车	600	545	730/810/810/890	4/4/5/4	50/90	Material: high quality cold rolling steel Q235B(SS400); Surface treatment: deoil, derusting and powder coat paint finish; Color: standard blue, orange and customized available
	600	545	890/970/1250	5/6/10	50/90	
	760	705	730/730/810/810	3/4/4/5	50/150	
	760	705	890/970/1250	5/5/7	50/150	
	1000	545	890	drawer: 2*100, 2*200mm & 2 pcs panel /drawer: 5*120, & 1 door, 1 adjust panel.	50/90	



tool cart



handle

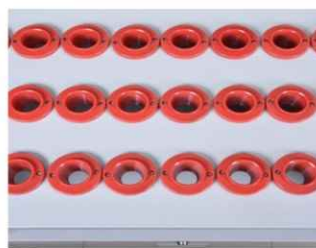

tool tray



Station Equipment 工位器具

WORKBENCH

◎工作台

Product Features:

- Sturdy table frame, can bear 1000kgs.
- A variety of desktop to choose such as : 50mm composite desktop.
- Laminate desktop; Beech desktop; Stainless steel desktop; fireproofing desktop; Metal desktop , to meet different usage requirements.
- The legs of the table are equipped with power sockets, which is convenient for operation.
- A variety of standard accessories; hanging panel, tool cabinets, lamps, vises, etc. to meet various operating requirements.

产品特性:

- 坚固的桌体框架，可承重1000kgs;
- 多种台面选择，例如：复合台面；高压合成板台面；榉木台面；不锈钢台面；防火台面；钢制台面。配合不同的使用要求；
- 桌腿配置电源插座，方便进行作业；
- 多种标准附件；挂板，工具柜，灯具，台钳等满足各种作业要求。



Station Equipment 工位器具

WORKBENCH

◎ 工作台

工作台常规尺寸表
Workbench Standard Size Sheet

名称 Name	Specifications(mm)			抽屉数量 (Drawer QTY) pcs	抽屉承载 (Drawer's Load Capacity) KGS	备注 (Remarks)
	宽度(Width)	深度 (Depth)	高度 (Height) included the feet height			
Workbench 工作台	1500	750	800	drawer: 2*100mm / 3*100mm	50/90/150	Material: high quality cold rolling steel Q235B (SS400);
	1800	750	800	drawer: 2*2*100mm / 2*3*100mm	50/90/150	
	2100	750	800	drawer: 3*200mm / 5*120mm	50/90/150	
	1500	750	800	drawer: 2*120mm, 1*160mm, 1*200mm,	50/90/150	
	1800	750	800	drawer: 2*100mm, door: 1 door	50/90/150	
	2100	750	800	drawer: LR:2*2*120mm, door: 2 door	50/90/150	
Workbench with hagning panel 挂板工作台	1500	750	800 (+900)	drawer: 2*120mm, 1*160mm, 1*200mm; hanging panel: 2*450mm	50/90/150	
	1800	750	800 (+900)		50/90/150	
	2100	750	800 (+900)		50/90/150	



sockets



4 drawers cabinet



hanging panel



50mm composite board of desktop



Station Equipment 工位器具

STORAGE CABINET

◎ 置物柜

Product Features:

- The heavy-duty storage cabinet is a fully enclosed metal storage device for placing items.
- It is suitable for warehouses, workshops and production office places to store tools (measurements), spare parts, instruments, drawings and other related items.
- Cooperating with accessory boxes, hanging boards, and drawer accessories can further increase the storage function of the storage cabinet, and can realize the unified management of factory equipment, tools, spare parts and other items.
- Multiple storage cabinet can form a partial partition of the workshop to achieve the purpose of efficient use of space that can not only separate the space but also store items.
- Steel decking with side beam hooking combination, the steel decking can be adjusted up and down; frame reinforced bottom beam, with adjustable foot cups.

产品特点:

- 重型储存柜是一种放置物品的全封闭式的金属储物器具。
- 适用于库房、车间和生产办公场所，存放工（量）具、零配件，仪器表和图纸资料等相关物品物料。
- 配合零件盒、挂板、抽屉配件可进一步增加置物柜的储存功能，能够实现对工厂设备、工具、零备件等物品的统一管理。
- 多台置物柜可以组成车间局部隔断，达到既能分隔空间又能存储物品的高效利用空间的目的。
- 层板侧梁挂接组合，层板上下可调；框架加固底梁，带调整脚杯。



Station Equipment 工位器具

STORAGE CABINET

◎ 置物柜

置物柜常规尺寸表
Storage Cabinet Standard Size Sheet

名称 Name	Specifications(mm)			抽屉/门/层板数量 (Drawer/Door/Decking QTY) pcs	抽屉/层板承载 (Drawer's/ Door's Load Capacity) KGS	备注 (Remarks)
	宽度(Width)	深度 (Depth)	高度(Height)			
Double door storage cabinet 对开门置物柜	1100	600	1950	3 adjust panel / 4 adjust panel / 2 adjust decking with 3+1 adjust decking	50/90/150	Material: high quality cold rolling steel Q235B (SS400); Surface treatment: deoil, derusting and powder coat paint finish; Color: standard blue, and customized available
	1100	600	1200	2 adjust decking	50/90/150	
Drawer storage cabinet 抽屉式置物柜	1100	600	1950	Bottom drawer or Middle drawer: 2*100mm / 3*100mm / *(2*100)mm ; decking: 2 adjust decking / 3 adjust declomg / 2*2 adjust decking	50/90/150	
Hanging panel storage cabinet 挂板壁柜	1100	600	1950	3+5 adjust panel ; 2 L hanging panel	50/90/150	
				2+2 adjust decking; 2 S hanging panel ; 1 S hanging panel in back	50/90/150	
				Middle drawer : 2*100mm ; 2 L hanging panel ; 1+1 adjust decking	50/90/150	
				Bottom drawer : 100mm ; 2 L hanging panel ; 5+1 adjust decking	50/90/150	



MATERIAL SORTING RACK

◎ 物料整理架

Product Features:

- Material sorting rack adopts the 5S concept, combined with back-hanging Accessory boxes of various colors and specifications and multi-purpose of square hole hook.
- Suitable for storage and transportation of a small amount with various small material tools, parts and special-shaped items.
- For material picking, mobile operations, Machine assembly, maintenance and other links can really achieve the purpose of improving efficiency and creating profits.

产品特点:

- 物料整理架运用5S观念，结合多种颜色规格的背挂零件盒和多用途的方孔挂钩。
- 适合少量多样的小型物料工具、零件及异形物品的存储搬运。
- 对于物料拣选，机动作业，机器组装、维修等环节可真正达到提高效率、创造利润的目的。



Station Equipment 工位器具

STEEL FILE CABINET

◎ 钢制文件柜

钢制文件柜常规尺寸表
Steel File Cabinet Standard Size Sheet

名称 Name	Specifications(mm)			抽屉/门/层板数量 (Drawer/Door/Decking QTY) pcs	抽屉/层板承载 (Drawer's/ Door's Load Capacity) KGS	备注 (Remarks)
	宽度(Width)	深度(Depth)	高度(Height)			
Steel File cabinet 钢制档案柜	460	600	700/1000/1300	Drawers: 2/3/4	50/90/150	Material: high quality cold rolling steel Q235B (SS400); Surface treatment: deoil, derusting and powder coat paint finish; Color: standard blue, green and customized available
	460	400	900/1060	Drawers: 6/7	50/90/150	
	900	400	740/1060	Doors: 4/6	50/90/150	
	900/960	410/300	1800/2000	Doors: 8/10	50/90/150	
	900	400/410	1060/1800	Doors: 2/4	50/90/150	
Steel Fitting cabinet 钢制更衣柜	980	480	1800/1900	Doors: 3/4/6/8	50/90/150	
Steel Storage cabinet 钢制储物柜	980	410	1900	Doors: 9/15/18/24	50/90/150	



WIRE MESH STORAGE CAGE

◎ 仓储笼

Product Features:

- Foldable structure ,saves space.
- Can be stacked four layers high, achieve three-dimensional storage.
- Cooperate with forklifts, lifts, cranes and other equipment to carry out , efficient operations.
- Surface treatment can be galvanized or power sprayed.
- Size can be customized.

产品特点:

- 折叠式结构，节省空间。
- 可互相堆叠四层高，实现立体化存储。
- 配合叉车、升降机、吊车等设备可进行高效作业。
- 表面处理可选择镀锌或喷涂。
- 尺寸可定制。

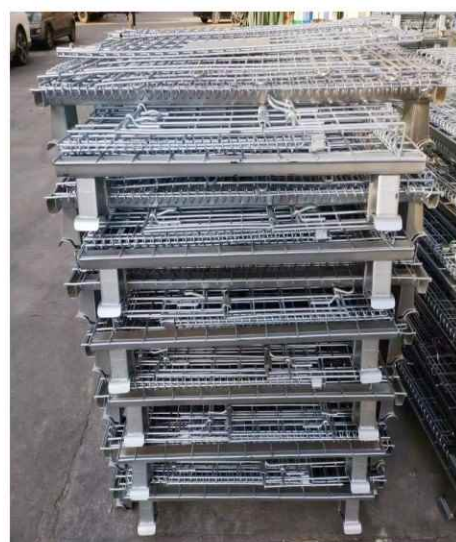

仓储笼常规尺寸表

Wire Mesh Storage Cage Standard Size

名称 Name	Specifications(mm)			线径 (Wire mesh dia) mm	网间隔 (Gridding) mm	承载 (Load Capacity) KGS
	长度 (Length)	宽度 (Width)	高度 (Height) included the feet height			
Wire mesh storage cage 仓储笼	800	600	640	5.8/5.6/5.3/4.8	50*50/50*100	800/600/400/200
	1000	800	840	5.8/5.6/5.3/4.8	50*50/50*100	1200/1000/600/300
	1200	1000	890	5.8/5.6/5.3/4.8	50*50/50*100	1500/1300/1000/600/300
	1000	800	500	5.8/5.6/5.3/4.8	50*50/50*100	800/600/400/200



STEEL MATERIAL CONTAINER

◎ 钢制料箱

Product Features:

- The Steel material container is divided into folding type and fixed type.
- It is especially suitable for items with irregular shape and heavy weight, such as automobile and accessory manufacturing industry, mechanical hardware processing industry.
- It has the characteristics of being turnable, stackable, storeable, and recyclable.

产品特点:

- 钢制料箱分为折叠式和固定式。
- 特别适用于形体不规则偏重型的物品，如汽车及配件制造业，机械五金加工业。
- 具有可周转，可堆垛，可储存，可循环等特点。



钢制料箱常规尺寸
Steel Material Container Standard Size

名称 Name	Specifications(mm)			堆垛层 (Stacking layer) layer	承载 (Load Capacity) KGS	表面处理 (Surface Treatment)
	长度 (Length)	宽度(Width)	高度(Height) included the feet height			
Steel Material Container 钢制料箱	800	500	600	4-6	800	Powder Coated/ Galvanized
	1000/1100	1000/1100	600	4-6	1500	Powder Coated / Galvanized
	1200	1000	600	4-6	1500	Powder Coated / Galvanized
	1000	800	850	4-6	1500	Powder Coated / Galvanized
	800	600	650	4-6	800	Powder Coated / Galvanized
	1100	1100	900	4-6	1000	Powder Coated / Galvanized
	1200	1000	900	4-6	1000	Powder Coated / Galvanized



Logistic Equipment 物流器具

FOLDING LOGISTICS TROLLEY

◎ 折叠式物流周转车

Product Features:

- Storage goods as classification, easy to manage;
- Assort with Circulation containers using to facilitate distribution of goods;
- Can fold storage to save space;
- Use high-quality steel production, durable using.

产品特点:

- 货物分类存放，易于管理；
- 配合周转箱使用，方便货物配送；
- 可折叠堆放，节省空间；
- 采用优质钢材制作，坚固耐用。



物流台车特点:

The characteristics of logistics cars

- 可配合卸货平台使用，方便货物装卸
- 可使生产暂存更为规范
- 可折叠收藏，不占空间
- 适用于生产线上零件分类存放，一目了然

折叠式物流周转车常规尺寸表

Folding Logistics Trolley Standard Size Sheet

名称 Name	Specifications(mm)			承载 (Load Capacity) KGS
	长度(Length)	宽度(Depth)	高度(Height)	
Folding Logistics Trolley 折叠式物流周转车	800	600	1700	500kgs
	850	650	1700	500kgs
	1100	800	1700	500kgs
	750	900	1700	500kgs
	860	725	1700	500kgs



STACKING FRAME

◎ 堆垛架

Product Features:

- Realize multi-layer stacking of goods and make full use of space.
- The goods are directly stored without additional pallets, which is convenient for forklift handling.

产品特点:

- 实现货物多层叠放，充分利用空间；
- 货物直接存储，不需另加托盘，方便叉车搬运；



堆垛架常规尺寸
Stacking Frame Standard Size

名称 Name	Specifications(mm)			堆垛层 (Stacking layer) layer	承载 (Load Capacity) KGS	表面处理 (Surface Treatment)
	长度 (Length)	宽度 (Width)	高度 (Height) included the feet height			
Stacking Frame 堆垛架	1200	1000/1100/ 1200	1500	5	600-1000	Powder Coated / Galvanized
	1250	1200/1400	1500	5/4	600-1000	Powder Coated / Galvanized
	1300	1100	1500	4	600-1000	Powder Coated / Galvanized
	1400	1200	1450	4	600-1000	Powder Coated / Galvanized
	1500	1250	1300	4	600-1000	Powder Coated / Galvanized
	1600	1320	1400	4	600-1000	Powder Coated / Galvanized



Logistic Equipment 物流器具

STACKING FRAME

◎ 堆垛架



ACCESSORY BOX

◎ 零件盒

零件盒常规尺寸
Accessory box Standard Size

名称 Name	Specifications(mm)			Color
	长度(Length)	宽度(Width)	高度(Height)	
Stackable accessory box 组立式零件盒	180	120	80	Blue, Yellow, Red
	250	150	120	Blue, Yellow, Red
	350	200	150	Blue, Yellow, Red
	400	250	160	Blue, Yellow, Red
	470	300	180	Blue, Yellow, Red
	520	350	190	Blue, Yellow, Red
	640	400	220	Blue, Yellow, Red
	620	400	220	Blue, Yellow, Red
Mounted accessory box 背挂式零件盒	135	105	76	Blue, Yellow, Red
	200	130	110	Blue, Yellow, Red
	276	139/213/279	128/128/178	Blue, Yellow, Red
	377	213/422	178	Blue, Yellow, Red



Mounted accessory box 背挂式零件盒

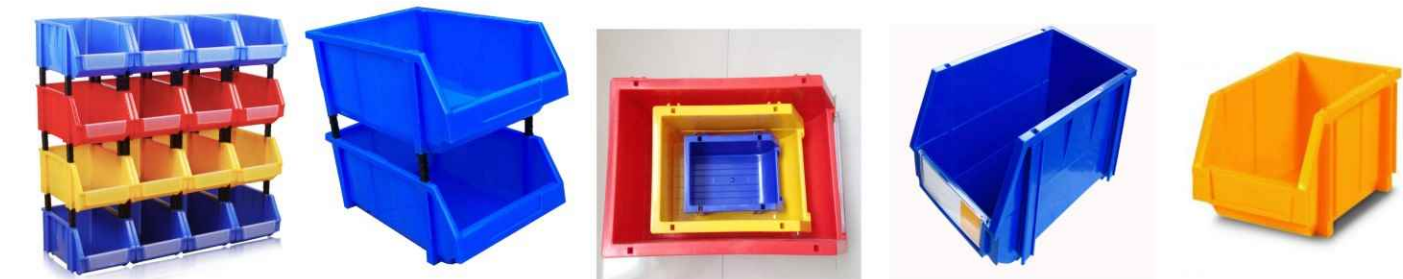

Stackable accessory box 组立式零件盒

PLASTIC PALLET

◎ 塑料托盘

塑料托盘常规尺寸 Plastic Pallet Standard Size

Picture	型号 Item No.	名称 Name	规格 Specification (L*W*H)	静载(T) Static Loading	动载 (T) Dynamic Loading	上货架 (T) Racking	进叉 Entry Type	Applicable Forklift
	GNF1280	网格九脚型 Grid Nine Feet Type	1200*800*145	2	0.6	-	四向进叉 4-way	Manual forklift, Electric forklift, Stacker
	GNF1111		1100*1100*145	2	0.6~0.8	-		
	GNF1210		1200*1000*145	2	0.5~1	-		
	GTFT1210	网格田字型 Grid "田" Font Type	1200*1000*150	3~5	0.8~1.2	1	四向进叉 4-way	Manual forklift, Electric forklift, Stacker
	GTFT1111		1100*1100*150	3~5	0.8~1.2	1		
	GTFT1311		1300*1100*150	5	1.5	1		
	GQFT1208	网格川字型 Grid "川" Font Type	1200*800*150	3~5	1~2	1	四向进叉 4-way	Manual forklift, Electric forklift, Stacker
	GQFT1111		1100*1100*150	3~5	1~2	1		
	GQFT1210		1200*1000*150	3~5	1~2	1		
	GQFT1211		1200*1100*150	3~5	1~2	1		
	GQFT1311		1300*1100*150	3~5	1~2	1		
	GDST1111	网格双面型 Grid Double Side Type	1100*1100*150	6	2	1.5	四向进叉 4-way	Electric forklift, Stacker
	GDST1210		1200*1000*150	6	2	1.5		
	GDST1212		1200*1200*150	6	2	1.5		
	FQFT1010	平板川字型 Flat "川" Font Type	1000*1000*150	5	1.5	1	四向进叉 4-way	Manual forklift, Electric forklift, Stacker
	FQFT1111		1100*1100*150	5	1.5	1		
	FQFT1210		1200*1000*150	5	1.5	1		
	FDST1010	平板双面型 Flat Double Side Type	1000*1000*150	5	1.5	1	四向进叉 4-way	Electric forklift, Stacker
	FDST1111		1100*1100*150	5	1.5	1		
	FDST1210		1200*1000*150	5	1.5	1		

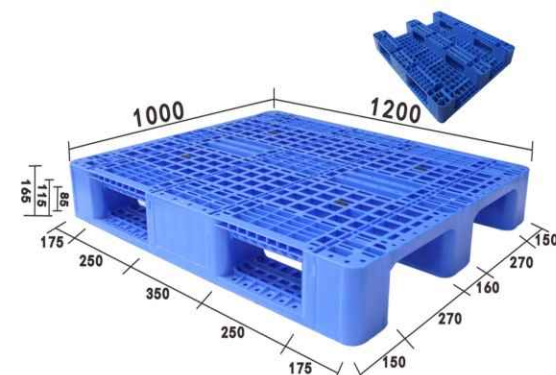

Grid "川" type
网格川字型 1210-165

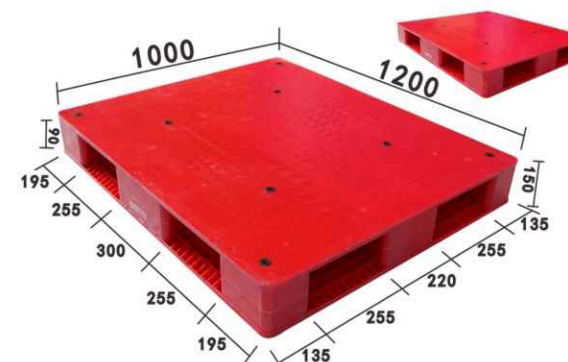

Flat double side type
平板双面型 1210-150

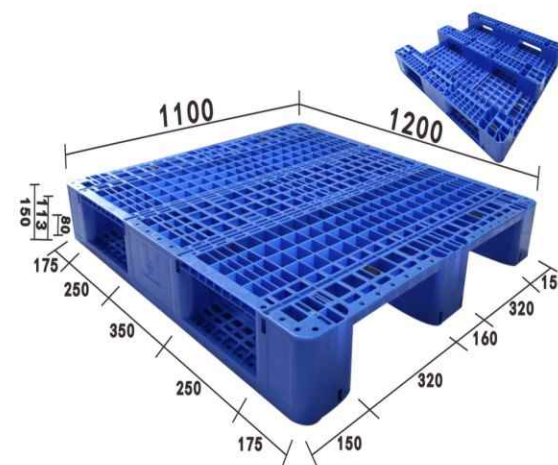

Grid "川" type
网格川字型 1211-150

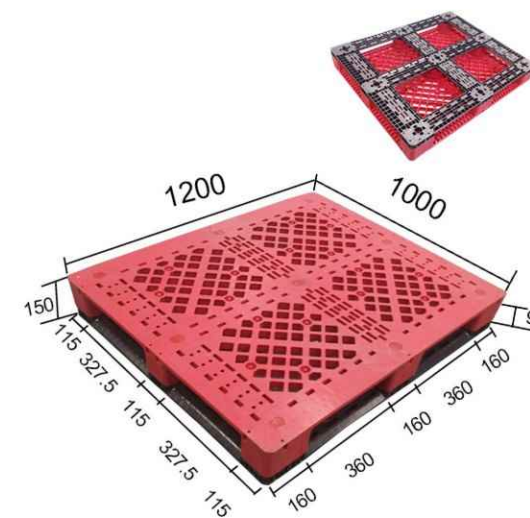

Grid "田" font type
网格田字型 1210-150

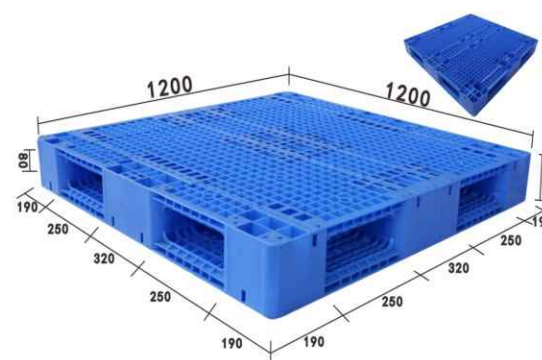

Grid double side type
网格双面型 1212-150

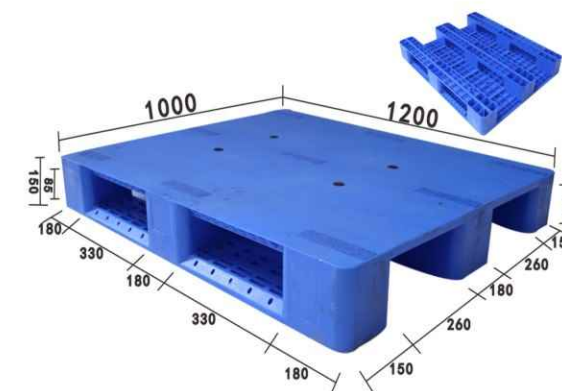

Flat "川" type
平板川字型 1210-150

Logistic Equipment 物流器具

PLASTIC PALLET

◎ 塑料托盘

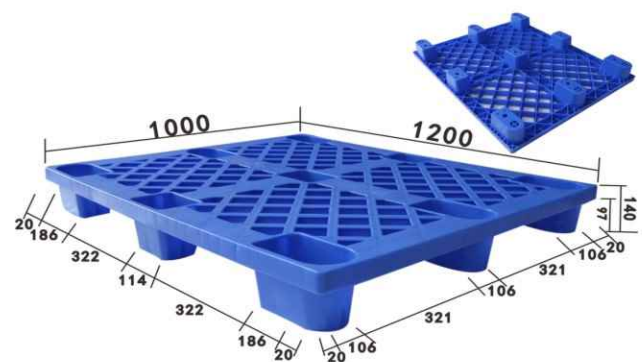

Grid double side type
网格双面型1111-150

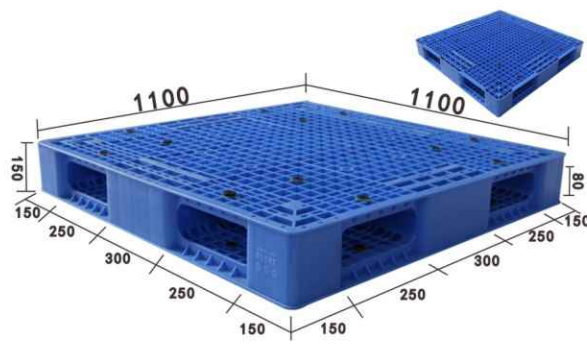

Grid nine feet
网格九脚型1210-140



TURNOVER BOX

◎ 周转箱

Product Features:

- Turnover box can be used for transportation, storage and distribution turnover.
- Product material: Anti-punching modified PP.
- The Bottom with rib design, so, the structure is more stable.
- Widely used in: breeding, food processing, medicine, clothing storage, electronics and other occasions.

产品特点:

- 可用于运输, 储存及配送周转;
- 产品材质: 抗冲压改性PP;
- 底部加强筋设计, 结构更稳定;
- 广泛应用于: 养殖, 食品加工, 医药, 服装收纳, 电子等各种场合。

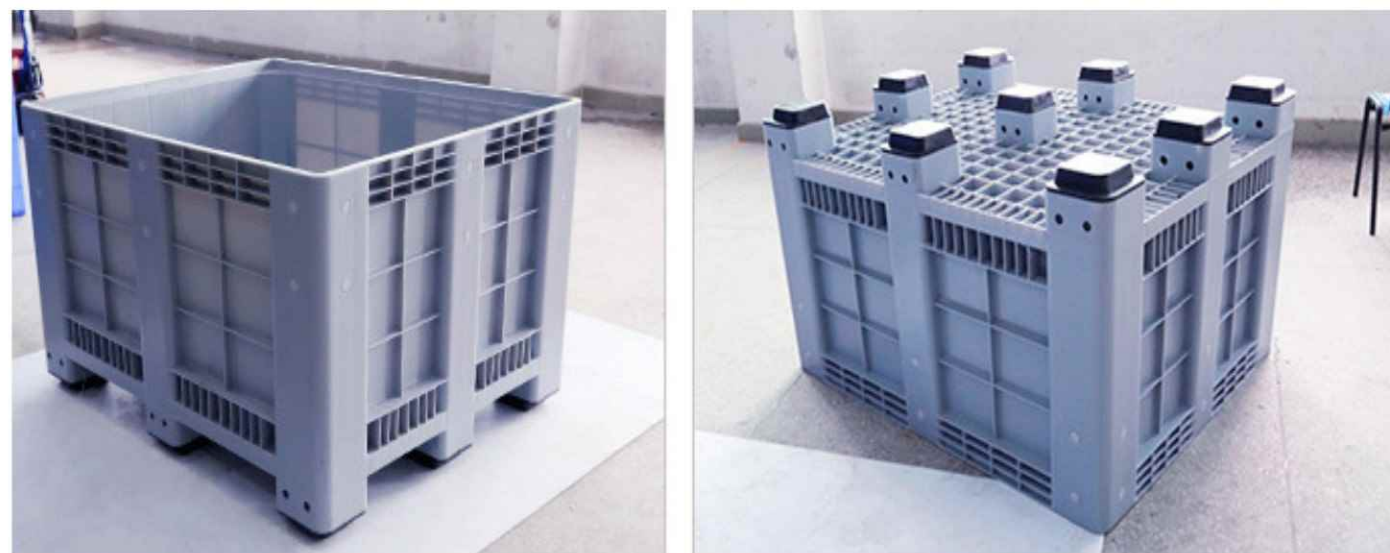
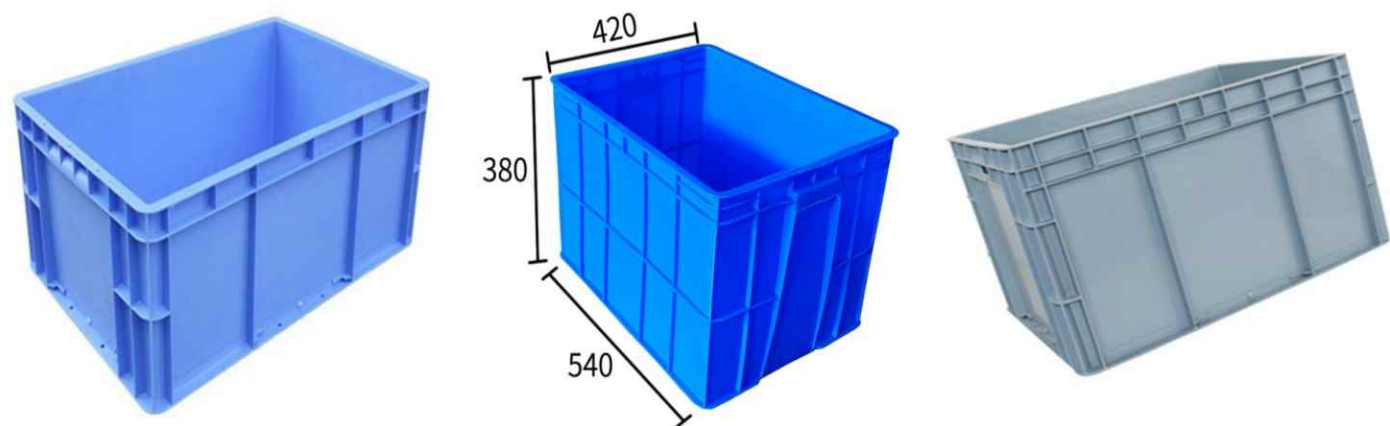

Logistic Equipment 物流器具

STEEL PALLET

◎ 钢制托盘

钢制托盘常规尺寸 Steel Pallet Standard Size

名称 Name	Specifications(mm)			承载 (Dynamic load) KGS	承载 (Static load) KGS	承载 (Rack) KGS	表面处理 (Surface treatment)
	长度(Length)	宽度(Depth)	高度(Height)				
Steel Pallet 钢托盘	1200	1200	125	1200-1500	4000	1200	Galvanized / Powder coated
	1200	1000	125	1500-2000	4000	1500	
	1100	1100	125	1500-2000	3500	1500	
	1200	1200	140	1200-1500	3500	1500	
	1200	1000	145	1200-1500	3500	1500	



Logistic Equipment 物流器具

WOODEN PALLET

◎ 木托盘

木托盘常规尺寸 **Wooden Pallet Standard Size**

名称 Name	Specifications(mm)			承载 (Dynamic load) KGS	承载 (Static load) KGS
	长度(Length)	宽度(Depth)	高度(Height)		
Wooden Pallet 木托盘	1200	800	144	1500	3000
	1200	1000	144	1500	3000
	1200	1000	120	1200	3000
	1140	1140	148	1500	3000
	1200	100	155	3000	5000

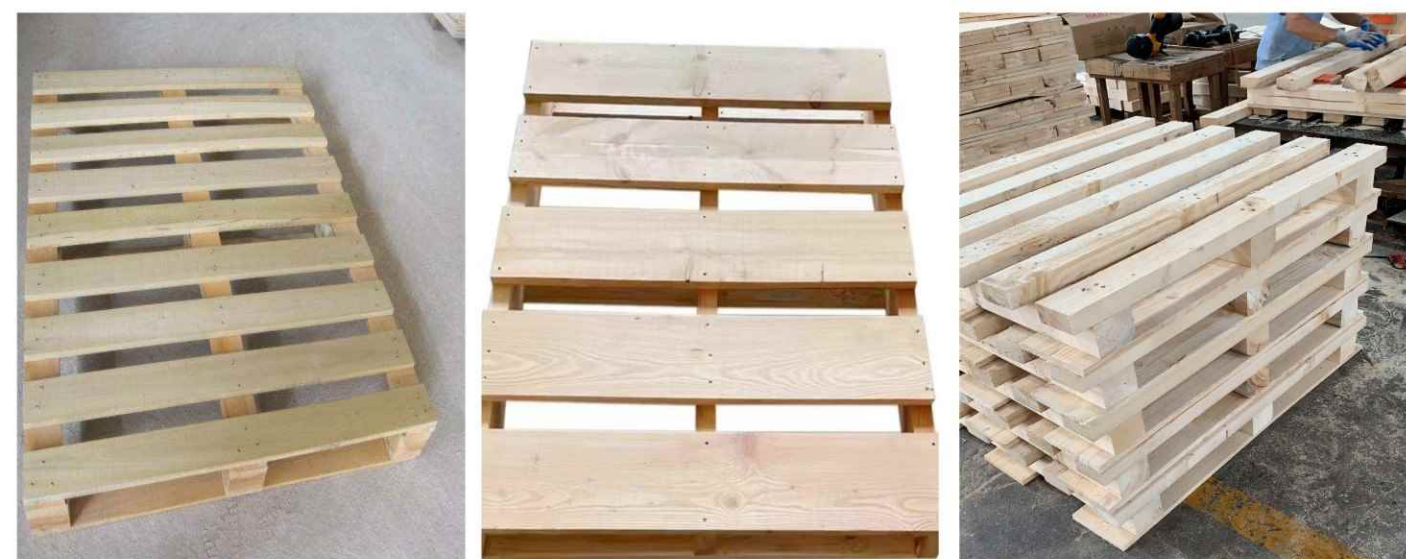
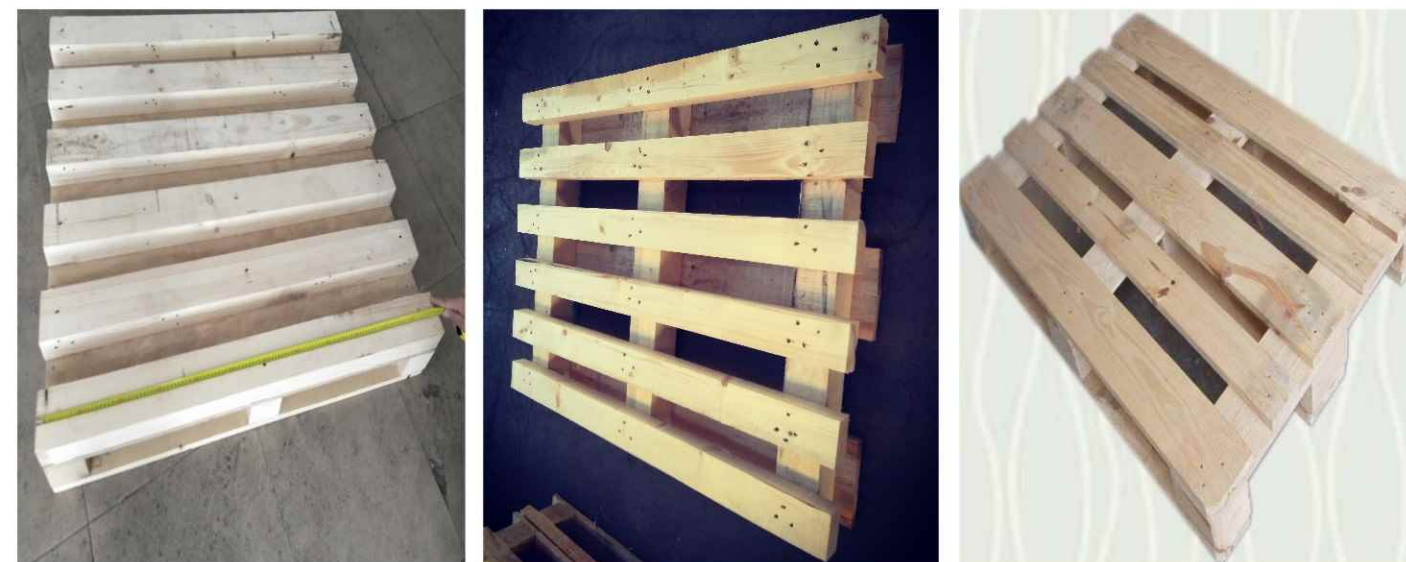

Transport Equipment 搬运设备

TROLLEY

◎ 手推车

• It is suitable for on-site production operations and storage with handling of materials. It can be customized in any style and specification.

• 适用于生产现场作业及物料的储存与搬运，可任意款式及规格订制。

手推车常规尺寸表
Trolley Standard Size Sheet

名称 Name	Specifications(mm)			脚轮 (casters)	承载 (Load Capacity) KGS	备注 (Remarks)
	宽度(Width)	深度 (Depth)	高度(Height)			
Assemble trolley 组装手推车	1095	575	1135	2 universal casters with brakes and 2 directional casters 2个带刹车的万向轮和2个定向轮	500	Material: high quality cold rolling steel Q235B(SS400); Surface treatment: deoil, derusting and powder coated.
	1010	498	1286		180	
	1425	525	1490		500	
	1290	510	840		150	
Noiseless trolley 静音手推车	730	490	890		150	
	825	500	860/890		200	
	910	600	890/920		300	



Transport Equipment搬运设备

MANUEL PALLET TRUCK

◎ 手动搬运车



DF3T

- 1.载重: 3000KG
- 2.货叉最低高度: 75MM
- 3.货叉最高高度: 190MM
- 4.货叉尺寸(外宽*长度): 550MM*1150MM/685MM*1220MM
- 5.轮子: PU 轮/尼龙轮



AC3T

- 1.载重: 3000KG
- 2.货叉最低高度: 85MM
- 3.货叉最高高度: 200MM
- 4.货叉尺寸(外宽*长度): 540MM*1150MM/685MM*1220MM
- 5.轮子: PU 轮/尼龙轮



SEMI-ELECTRIC STACKER

◎ 半电动堆高车

详细参数 PS1646W



	model		PS1646W
	power		electric
	Driving style		stand
	Load capacity	Q(kg)	1600
	Load center distance	C(mm)	600
	Front suspension	x(mm)	784
	Wheelbase	y(mm)	1336
重量	Self weight (Including battery)	Kg	1450
	Bridge load at full load Drive wheel side / load side wheel side	Kg	1400/1650
	Bridge load at no load Driving wheel side / load bearing wheel side	Kg	1130/320
基本尺寸	Height when the gantry is retracted	h1(mm)	2102
	Free lift height	h2(mm)	-
	lift height	h3(mm)	4515
	Maximum height of the gantry during operation	h4(mm)	5112
	Handle height during work, maximum/minimum	h14(mm)	1396/961
	Fork height when the gantry is retracted	h13(mm)	85
	Overall length	l1(mm)	1895/1995
	Body length	l2(mm)	746/846
	Body width	b1(mm)	1050
	Fork size	s/e/l(mm)	60/180/1150
	Outer fork width	b5(mm)	570/685
	Minimum ground clearance	m2(mm)	25
	Channel width 1000X1200 Placed across the fork	Ast(mm)	2400/2500
	Channel width 800X1200 Placed along the fork	Ast(mm)	2350/2450
Turning radius	Wa(mm)	1550/1650	
性能	Driving speed Full load / no load	km/h	6.0/6.0
	Lifting speed Full load / no load	m/s	0.10/0.16
	Falling speed Full load / no load	m/s	0.095/0.12
	Maximum climbing capacity Full load / no load	%	6/12
电机	Drive motor power	kw	1.3
	Increase motor power	kw	3.0
	Battery voltage / capacity	V/Ah	24/280

Transport Equipment搬运设备

SEMI-ELECTRIC STACKER

◎半电动堆高车

Details Data RT1675

	特性	1.2	Model Number		RT1675	
		1.3	Power		electric	
		1.4	Driving style		seated	
		1.5	specified load	Q (t)	1.6	
		1.6	Load center distance	c (mm)	600	
		1.8	Front suspension	x (mm)	180	
		1.9	Wheelbase	y (mm)	1400	
		重量	2.1	Self weight (including battery)	kg	3850
			4.1	Fork tilting front/back	α/β (°)	2/4
	基本尺寸	4.2	Gantry retraction height	h1 (mm)	3167	
		4.3	Free lift height	h2 (mm)	2255	
		4.4	Lift height	h3 (mm)	7500	
		4.5	Maximum height of the gantry during operation	h4 (mm)	8415	
		4.7	Roof guard height	h_6 (mm)	2160	
		4.19	Overall length	l_1 (mm)	2285	
		4.20	Length to the vertical side of the fork	l_2 (mm)	1215	
		4.21	Body width	b_1 (mm)	1260	
		4.22	Fork size	s/e/l (mm)	35/100/1070	
		4.25	Outer fork spacing (min/max)	b_5 (mm)	200/755	
4.28		Forward distance	l_4 (mm)	600		
4.31		Minimum ground clearance	m_1 (mm)	75		
4.34		Right angle stacking channel width 800×1200 (1200 placed along the fork)	Ast (mm)	2735		
4.35		Turning radius	Wa (mm)	1655		
4.37		To the front end of the wheel arm	l_7 (mm)	1765		
性能	5.1	Driving speed Full load / no load	km/h	10.5/10.5		
	5.2	Lifting speed Full load / no load	m/s	0.27/0.34		
	5.3	Falling speed Full load / no load	m/s	0.50/0.40		
	5.4	Forward speed Full load / no load	m/s	0.15/0.20		
	5.8	Maximum climbing capacity Full load / no load	%	10/15		
	5.10	Service brake		Electromagnetic brake		
电机	6.1	Drive motor power S2 60min	kW	6.4		
	6.2	Increase motor power S3 15%	kW	12.5		
	6.3	Battery according to DIN 43531/ 35/ 36 A, B, C,		A,4Pzs		
	6.4	Battery voltage, rated capacity K5	V/ Ah	48/360-450		
	6.5	Battery weight	kg	750		
其它	8.1	Drive control method		Three-phase		
	8.2	System pressure	(bar)	160		
	8.3	System traffic	(l/min)	35		
	8.4	Driver's ear noise level according to EN12053	dB(A)	<70		

Electric Stacker

◎全电动堆高车

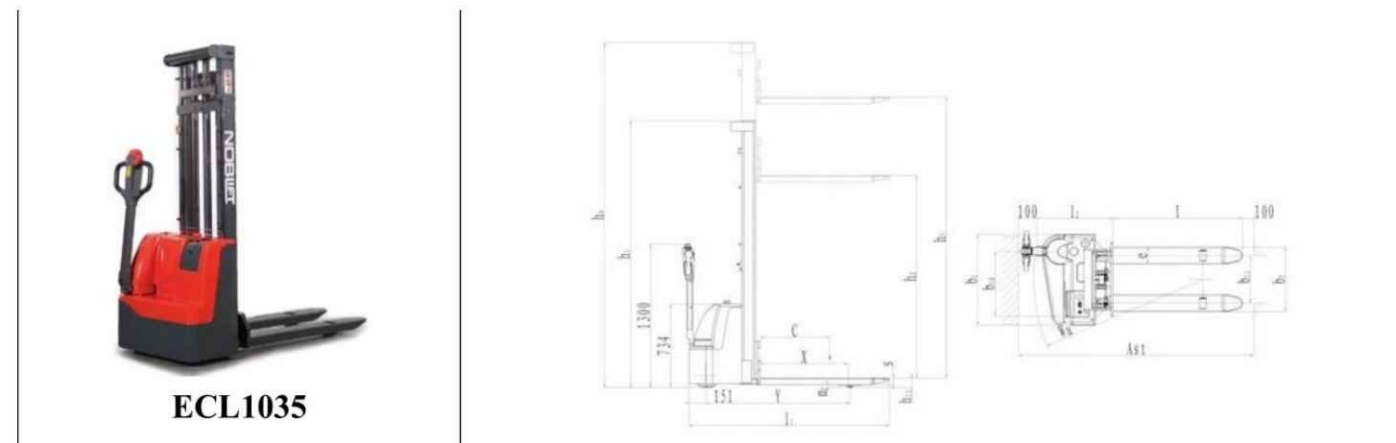

1. 技术参数/Technical specifications

原产地	Country Original	中国
型号	Model	ECL1035
动力	Power Unit	electric
操作型式	Operation Type	pedestrian
额定负载	Rated Capacity	1000Kg
提升高度	Lift Height	3440mm
车宽	Overall Width	800mm
车长	Overall Length	1800mm
货叉长度	Fork Length	1150mm
货叉外宽	Width Across Fork	570/685mm
转弯半径	Turning Radius	1485mm
自重	Self	540kg
升降马达功率	Lift Motor Rating	2.2kw
电瓶电压/额定容量	Battery	2*12V/85Ah

全电动堆高车 ECL1035



Transport Equipment搬运设备

ELECTRIC STACKER

◎全电动堆高车



PS1560

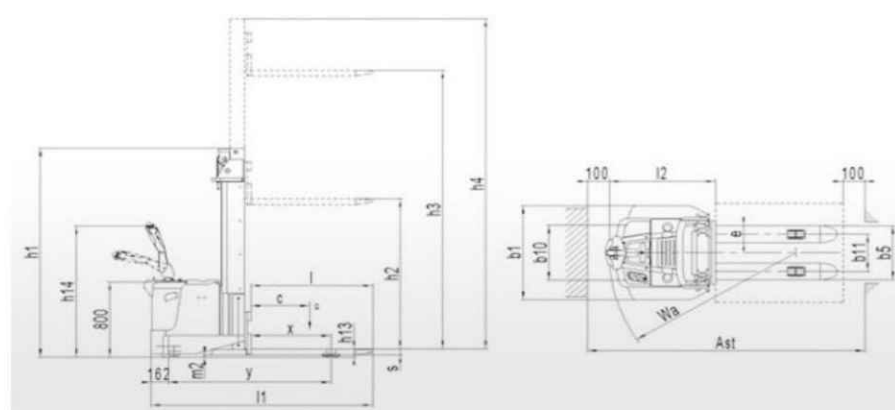

PSB1229

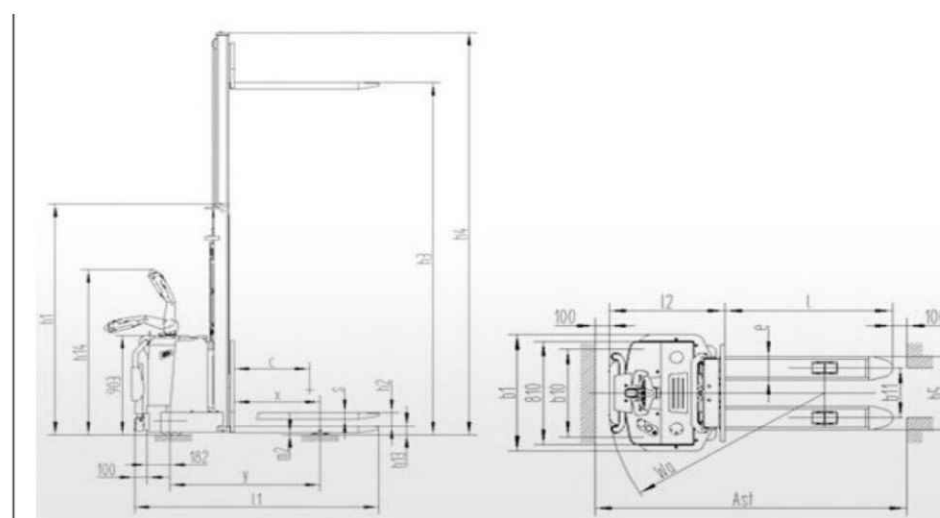

Technical specifications

Item		PS1560	
characteristic	Motive power	Electric	
	Driving way	walking type / stand type	
	Load	Q(KG)	1500
	Load center distance	C(mm)	600
	Front overhang	x(mm)	751
	Wheel base	y(mm)	1650
	weight	weight(include battery)	kg
Heavy load wheel side		kg	1345/1663
Empty load wheel side		kg	955/553
size	The height of the forklift door frame retract	h1(mm)	2740
	Free lift height	h2(mm)	2100
	Lifting height	h3(mm)	5915
	Lift max height	h4(mm)	6600
	Handle height,max/min	h14(mm)	1370/945
	Lift retracted fork height	h13(mm)	85
	Overall length	i1(mm)	2193
	Truck length	i2(mm)	1043
	Truck depth	b1(mm)	1000
	Fork size	s/e/i(mm)	60/180/1150
	Fork Width	b5(mm)	570/685
	Min. ground clearance	m2(mm)	25
	Channel width 1000*1200 cross fork	Ast(mm)	2660
	Channel width 800*1200 along fork	Ast(mm)	2612
	Turing radius	Wa(mm)	1810
	performance	Moving speed full load/empty load	km/h
Lifting speed full load/empty load		m/s	0.141/0.212
Fall speed full load/empty load		m/s	0.196/0.178
Max gradeability full load/empty load		%	6/12
Service brake			Electromagnetic brake
motor	Drive motor power	kw	1.3
	Lift motor power	kw	3
	Battery voltage/capacity	V/Ah	24/350
	Battery weight +/-5%	kg	288

技术参数/Technical specifications

原产地	Country Original	中国	全电动堆高车 PSB1229
型号	Model	PSB1229	
动力	Power Unit	Full electric	
操作型式	Operation Type	Standing drive type	
额定负载	Rated Capacity	1200Kg	
负载中心	Load Centre	600mm	
提升高度	Lift Height	3200mm	
静止高度(最少)	Close Height Min	1946mm	
主门架伸展(最高)	Height of Mast Max.	3276mm	
车宽	Overall Width	796mm	
车长	Overall Length	1908mm	
货叉长度	Fork Length	1150mm	
货叉外宽	Width Across Fork	570mm	
转弯半径	Turning Radius	1485mm	
转弯通道	Transfer Asile Width(800X1200板)	2256mm	
自重	Self	900kg	
行车马达功率	Drive Motor Rating	1.3kw	
升降马达功率	Lift Motor Rating	2.2kw	
行车速度	Travel Speed 0/1	6.0/6.0km/h	
升降速度	Lifting Speed 0/1	110/120mm/s	
制动型式	Brake	电磁制动	
电瓶电压/额定容量	Battery	24/210V/5Ah	
充电器	Charger	24V/30A	



Transport Equipment搬运设备

FORKLIFT

◎ 叉车

Details data for FE4P25N

	Item		FE4P25N
characteristic	Power		electric
	Operation method		Seated
	load capacity	Q (kg)	2500
	Load center distance	c (mm)	500
	Front suspension	x (mm)	468
	Wheel distance	y (mm)	1500
Weight	Self weight (including battery)	kg	4260
	load drive side / load bearing side at full load	kg	6010/750
	load drive side / load bearing side at unload	kg	1940/2320
Tire	Tire		Solid tire
basic size	Door frame / fork frame tilt angle (front / rear)	$\alpha/\beta(^{\circ})$	6/10
	Door frame retraction height	h1(mm)	2045
	Freely lift height	h2(mm)	120
	Lift height	h3(mm)	3000
	Door frame expansion height	h4 (mm)	3977
	Roof guard height	h5(mm)	2190
	Seat height	h6(mm)	1100
	Traction pin height	h7(mm)	295
	Overall length	l1 (mm)	3393
	Body length (excluding forks)	l2 (mm)	2328
	Total width	l3(mm)	1260
	Fork size	s/e/l(mm)	1070
	Fork width	b5 (mm)	1040
	Ground clearance below the door frame	m1 (mm)	110
	Wheelbase center ground clearance	m2(mm)	120
	performance	Driving speed full load / no load	km/h
Lift speed full load / no load		m/s	0.30/0.39
Falling speed full load / no load		m/s	<0.6
Traction full load / no load S260 minutes		N	10000/7000
Climbing ability full load / no load S25 minutes		%	13/15
Service brake			Hydraulic
Motor	Drive motor power	kW	11
	Lift motor power	kW	8.6
	Battery voltage / capacity	V/ Ah	48/600

