



GUANGDONG ORION INTELLIGENT EQUIPMENT LIMITED

广东奇力智能设备有限公司



# HIGH-PERFORMANCE SHUTTLE

## 高性能穿梭车



Jasmine

Web : <http://www.orionrack.com>  
E-mail : [jasminezhao@orionrack.com](mailto:jasminezhao@orionrack.com)  
[lucky@orionrack.com](mailto:lucky@orionrack.com)  
Tel: +86 13424131725  
Sevrice Hotline: +86-400-801-8665



Lucky

# TWO-WAY SHUTTLE

## 两向穿梭车



### Features of the two-way shuttle:

1. High working efficiency, significantly reducing working hours;
2. Good stability, reducing shelf collisions;
3. High-density storage, with warehouse utilization is 30% higher than the single-stack warehouses;
4. Flexible operation mode;
5. Access goods can adopt the FIFO or FILO methods.

### 两向穿梭车特点：

1. 工作效率高，大大减少工作时间；
2. 稳定性好，减少货架碰撞；
3. 高密度存储，仓库利用率比单道堆垛仓库高30%；
4. 灵活的操作方式；
5. 存取货物可采用先进先出、先进后出的方式。

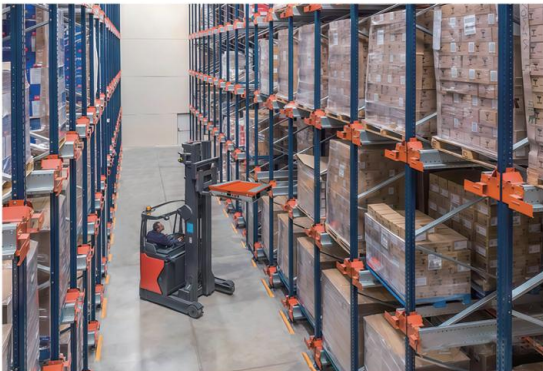

# Two-way shuttle parameter

## 两向穿梭车技术参数

序号 Item	规格指标 Specification	参数 Parameter
1	穿梭车外形标准尺寸 (mm) Standard dimensions of the shuttle	L1120*W960*H170 (可定制) Customizable
2	载荷 Load	标准版 800Kg-1500Kg (可定制) Standard version 800Kg-1500Kg (customizable)
3	空载速度 No-load speed	0-60m/min
4	满载速度 Full-load speed	30-35m/min
5	升降高度 Lift height	≤45mm
6	作业时长 Working hours	6-8h
7	电机功率 Motor power	750W
8	电池电压 Battery voltage	锂电池48V Lithium battery: 48V
9	电池容量 Battery capacity	50Ah
10	电池续航能力 Battery life	满载4-6h Full load 4-6h
11	常温下充电时间 Charging time at room temperature	2h
12	正常使用电池寿命 Normal battery life	2000次 2000times
13	显示屏 Display screen	液晶 Liquid crystal
14	电源 Power supply	锂电池48V Lithium battery: 48V
15	工作电压 Working voltage	5V
16	待机功能 Standby function	48h+
17	电池 Battery	持续作业24h以上 Continuous operation 24h+
18	控制方式 Control mode	手动、单机半自动、系统自动控制 Manual, single-machine semi-automatic, system automatic control
19	功能 Function	单次存取货、连续存取货、盘点等 Single access to goods, continuous access to goods, inventory taking, etc

# FOUR-WAY SHUTTLE

## 四向穿梭车



Features of the four-way shuttle:

1. High efficiency and flexibility: Run both longitudinally and laterally, adapting to complex scenarios;
2. High degree of automation: It can achieve multiple automatic functions;
3. High storage density: It can move through multiple layers within the roadway, achieving high-density storage of goods;
4. High safety: Equipped with multiple protection devices.

四向穿梭车的特点：

1. 高效灵活：既能纵向行驶也能横向行驶，适应复杂场景；
2. 自动化程度高：可实现多种自动功能；
3. 存储密度大：可在巷道内多层穿梭，实现货物高密度存储；
4. 安全性高：配备多种保护装置。



# Four-way shuttle parameter

## 四向穿梭车技术参数

项目名称 Item		技术参数 Parameter
额定载重量 Rated load capacity		1500kg (可定制) Customizable
水平 行走 Horizontal working	行走驱动方式 Walking drive mode	伺服驱动 Servo drive
	制动方式 Braking mode	电磁刹车制动 Electromagnetic brake braking
	定位 (X向) 精度 Positioning (X direction) accuracy	$\leq \pm 3\text{mm}$
	满载最大速度 Maximum speed under full load	35m/min
	空载最大速度 Maximum speed no load	70m/min
	货叉 Fork	驱动方式 Drive mode
	定位方式 Positioning method	编码器+光电 Encoder + Photoelectric
	顶升时间 Lifting time	4s
通讯方式 Communication method		无线通讯 Wireless communication
控制方式 Control mode		西门子PLC控制 Siemens PLC control
操作方式 Operation mode		半自动/自动 Semi-automatic/automatic
屏幕 Screen		触摸屏 Touch screen
供电方式 Power supply mode		电池供电 Battery power supply
电源规格 Power supply specification		48V
单机噪音 (高速满载) Single-machine noise (high speed and full)		$\leq 65\text{dB}$

# Structure diagram of Radio-shuttle rack 穿梭式货架结构图

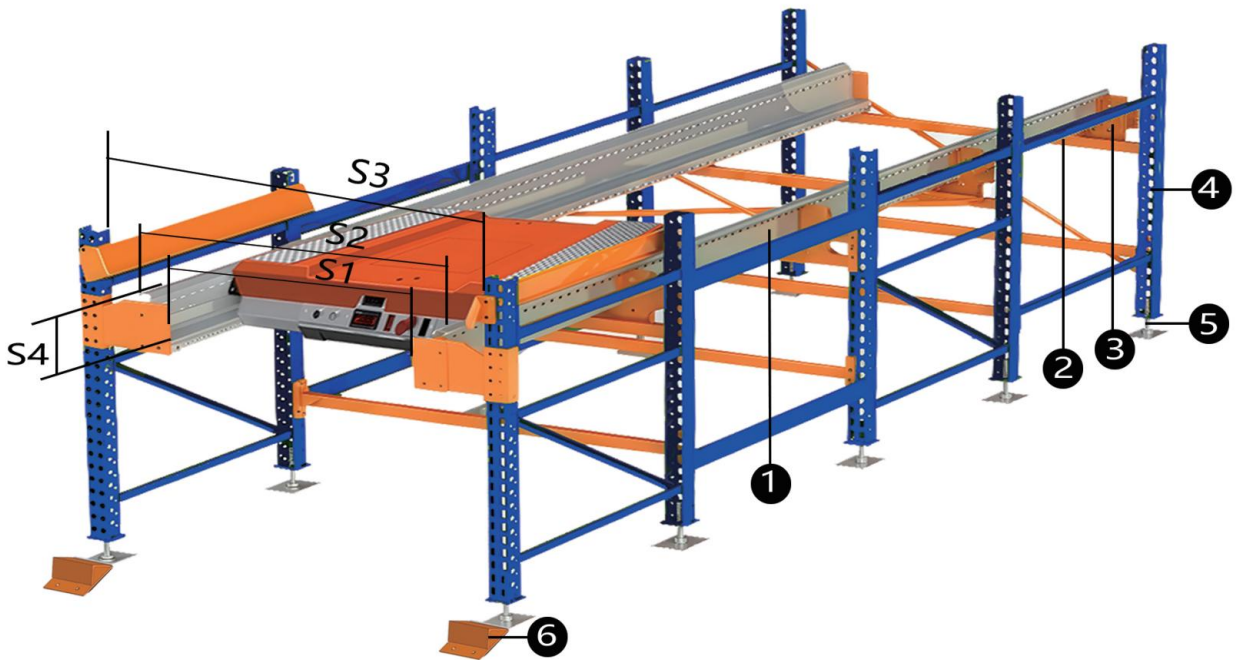

1.Rail 轨道

2.Crossbeam 横档

3.Rail support plate 轨道支撑板

4.Upright Post 货架立柱

5.Adjustable footing 可调底脚

6.Forklift baffle 叉车挡板

S1.Inner width of rails 轨道内宽

S2.Outer width of rails 轨道外宽

S3.Inner width of upright posts 立柱内宽

S4.Height of rail 轨道高度

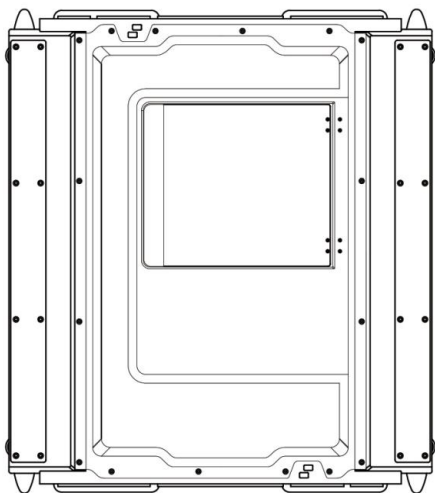

Top view  
俯视图

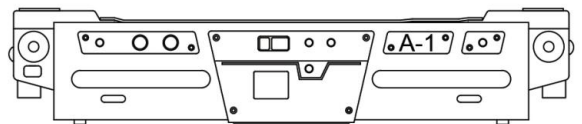

Front view  
正视图

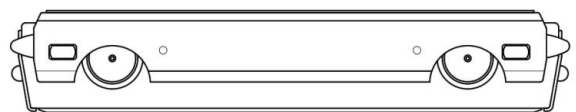

Side view  
侧视图

# The usage method of shuttle

## 穿梭车使用方式

According to the layout of the access ports for goods, it can be divided into First-in-First-out (FIFO) and First-in-Last-Out (FILO).

根据货物的存取端口布置，可分为先进先出模式(FIFO)和先进后出模式(FILO)。

### FIFO

#### 先进先出

- 1.The goods are stored at one side and retrieved at the other side of the roadway;
- 2.Must be arranged forklift channels in two side;
- 3.Suitable for accessing goods with expiration date requirements.

1. 货物从一端存入，巷道另一端取出；
2. 货架两端均需要布置叉车通道；
3. 适合存取有保质期要求的货物；

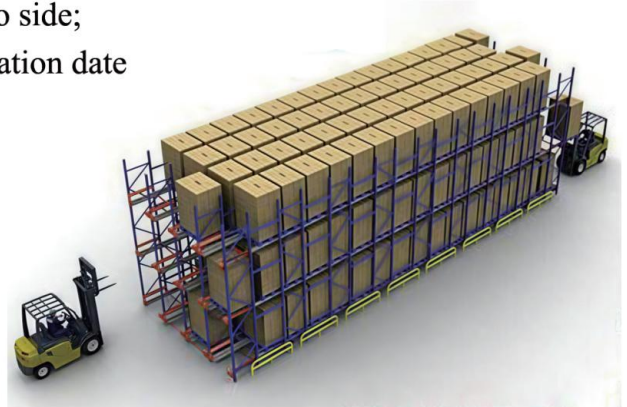

### FILO

#### 先进后出

- 1.Forklift passageways are only arranged on one side of the shelves;
2. It can make the most of the warehouse area;
3. Suitable for occasions where the sequence of material entry and exit has low requirements.

1. 仅在货架单侧布置叉车通道；
2. 能最大限度的利用仓库面积；
3. 更适合对物料进出顺序要求低的场合



# Structural annotation of the shuttle 穿梭车结构注解

Drive motors 行走与驱动电机

Lift up mechanism 顶升机构

A new type of four connecting rods lifting mechanism, whole lift up horizontally  
采用整体平行四连杆顶升机构，顶升平稳

Pallet laser position sensors 托盘激光定位

Laser sensors for detecting the pallets position  
激光传感器,精密测距定位

Rail terminal distance sensors 轨道侧极限测距

Far-infrared sensors for measuring distance from the rail terminal plates  
远红外传感器,精密测距定位

Buffering posts 缓冲柱

Protect the vehicle at rail terminal  
用于穿梭车端头安全缓冲

On/off buttons 开、关按钮

Adopting metal buttons embedded for vehicle start or stop, and also defend the attack from falling parts  
内嵌式金属开关按钮，可避免货物撞击按钮导致损坏

LCD display screens 台车显示屏

Show operation model, stock check and displaying the error code numbers.  
可显示运行模式、盘点数字、故障代码显示

Energy storage mechanism

Saving the batteries energy, prolonging the endurance

能量储存机构  
节约电能，延长续航能力

Streamlined appearance

流线型外观

Running led light 运行闪烁灯

Adopting metal LED lights embedded, flashing when running  
内嵌式 LED 金属指示灯，行走闪烁提示

Batteries level indicators

电池电量灯  
Showing L1\L2 battery level individual  
单个电池L1、L2低电量独立显示

Track extreme deceleration process hole, triple security control technology.

轨道极限减速工艺孔，三重安全控制技术

Forklift bumping blocks

叉车防撞挡条  
Defend vehicle from the forklift  
避免叉臂对车的撞击

Cleaning blades 轨道刮板  
Keep the track clean  
保持轨道清洁畅通

Running wheels 行走轮

High friction, high toughness  
高摩擦、高耐性

